



# *Rental Catalog*

2022

**San Diego Stage & Lighting Supply, Inc.**

2203 Verus Street

San Diego, Ca 92154

(619) 299-2300

(619) 299-0058 Fax

[www.sdstagelighting.com](http://www.sdstagelighting.com)

*San Diego's Leading Theatrical, Lighting and Stage Supply*

*Established 1974*

**California License # 822754**

## TABLE OF CONTENTS

General Info	Page 1	Mirror Balls & Accessories	Page 8
		Fans & Wind Machines	Page 8
Frequently Asked Questions	Page 2	Black Lights/ UV Lights	Page 8
Glossary	Page 3	Strobe Lights	Page 8
		Dimming	Page 8
Ellipsoidal Spots	Page 4	Lighting Consoles	Page 8
Fixture Accessories	Page 4	LED Video Wall	Page 8
Hanging Hardware	Page 4		
Fresnels	Page 4	Moving Light Cable	Page 9
Incandescent Par Fixtures	Page 4	Socopex Cable	Page 9
LED Par Fixtures	Page 4	Control Cables (DMX, AMX, XLR)	Page 9
		Cables	Page 9
Floods	Page 5	Scaffold	Page 11
Cyc Lights	Page 5	Rigging & Chain Motors	Page 11
Striplights	Page 5	Pipe & Pipe Hardware (Booms)	Page 11
Opto Isolators, Demux, Wireless DMX	Page 5	Tradeshaw & Party Equipment	Page 11
Search Lights	Page 5		
Followspots	Page 5	Staging	Page 12
Uplight Kits	Page 5	Choir Risers	Page 12
		Drape & Drape Hardware	Page 12
Stage Lighting Kits	Page 6	Spandex	Page 12
Film Lighting Kits	Page 6	Scrims & Cycloramas	Page 12
Stringer/twinkle lights	Page 6		
Flicker Effects	Page 6	Wedding Flyer	Page 13
LED Backdrop	Page 6	Performance Charts	Page 14
LED Special Effect Lights	Page 6		
		General Contract Terms	Page 15
Special effect lights	Page 7		
Bubbles/Flames	Page 7		
Centerpiece Effects	Page 7		
Lasers	Page 7		
Smoke/Fog/Haze/Low lying fog Effects	Page 7		
Snow Machines	Page 7		
Intelligent Lighting & Controllers	Page 7		
Music Stands & Lights	Page 7		
Confetti Cannons	Page 7		
Clear Com	Page 7		
(PBG, SPG, IEC, TLG, Power-Con)			
Two-Fers & Adapters	Page 9		
Distro Panels & Spider Boxes	Page		
10			
Electrical Distribution	Page		
10			
Disconnects/Switches	Page 10		
Transformers	Page 10		
Cable Ramps	Page 10		
Lifts & Towers	Page 11		
Truss	Page 11		

## **Hours**

Shop hours are Monday through Friday  
8am to 4pm

## **Rental Period**

The minimum rental period is one day.  
The week rate is for up to seven days.

## **Terms**

All rentals must be paid in full at the time the equipment is released, unless a customer credit account has been established and is good standing. Applications for credit accounts will only be considered for customers utilizing the account on a monthly basis. Rentals may be paid with cash, imprinted checks, MasterCard, Visa, or Discover. Only imprinted checks will be accepted on approval with a valid California Drivers license or other acceptable picture identification.

## **Rental Deposit**

A deposit is required on all rentals to non-account customers. Deposits may be paid in cash or major credit card. Checks will not be accepted. A deposit up to the value of all equipment rented may be required. A valid California Drivers license or other acceptable ID is required to be shown at the time of pick up of the rental equipment.

## **Taxes**

SDSL rentals are not subject to California sales taxes.

## **Certificate of Insurance**

The renter is responsible for and will provide insurance to cover the retail sales value of equipment rented and for all loss or damage.

SDSL reserves the right to request a certificate of insurance for any order.

**San Diego Stage & Lighting reserves the right to modify or change pricing at any time.**

## **Returns**

All equipment is due back at 11am on the specified return date. Equipment not returned by 11am will be charged for that day at the day rate.

## **Liability**

SDSL is in no way responsible for liability, claims, costs or expenses rising out of the use or possession of said equipment. Equipment is offered for inspection and test at the time of rental. SDSL assumes the

customer acknowledges that only qualified stagehands and other professionals will be operating rental equipment.

## **Missing or Damaged Equipment**

The customer is responsible for equipment picked up at or delivered by SDSL. Equipment is released to the customer with a signed receipt. The customer is responsible for returning the equipment to SDSL.

Rental charges continue until equipment is returned or until an invoice for the replacement is issued and paid. Rental charges will not be deducted from the replacement cost.

## **Delivery and Pick Up**

SDSL can supply delivery and pickup services for a fee. Pickup and delivery service includes transportation only. The customer must provide labor to unload, load, install and/or remove equipment. SDSL can provide these services at an additional charge. Please ask for a quotation in advance.

## **Shipping**

Air and ground transportation will be provided at the customer's expense. All rental equipment returned to SDSL must be shipped prepaid. The rental does not end until equipment is received at our warehouse.

## **Reservations**

Rental reservations are suggested as all equipment is rented on a first come first served basis.

A rush charge of up to 50% may be assessed for day of event rental requests.

## **Extensions**

Rentals are for a specified period. Extensions must be approved and paid for in advance and are subject to availability.

# Frequently Asked Questions

---

## **What size stage do I need?**

Typically for a 5-piece band, the minimum size of the stage will be 16' x 12', larger if you have active dancers. Here are some typical layouts:

12' x 8'

16' x 12'

24' x 12'

24' x 32'

All our staging can be customized to any size that you need.

## **Here are some staging questions to have in mind:**

What are the dimensions of the room (if indoors)?

Is the ground level (if outdoors)?

What is happening on the stage i.e. a standing speaker; a hip hop band; a graduation ceremony; a high school play, etc.

What is my budget?

## **How much and what kind of lighting do I need?**

Different spaces and different events require different lighting. Weddings typically include some uplighting, a gobo and maybe some accent lighting.

Concerts can have full moving light rigs.

Meetings can go from small uplighting packages to full concert style lighting.

## **Please keep these questions in mind when inquiring about lighting:**

What size of an area am I trying to cover?

What kind of lighting am I looking for? i.e. Accent lighting; General Area Lighting; Stage lighting; Special effects

How much power do I have available to me? Do I need LED lighting?

Do I need to dim and or control the lighting?

Do I want to be able to change colors?

## **What size truck do I need to pick up my order?**

Well that all depends on how much equipment you are picking up and or returning.

A smaller follow spot will fit in just about any car (maybe not a SmartCar)

A couple of 4' x 8' stage pieces can fit into a pickup truck, more in a full size or larger pickup truck.

Our lighting kits can typically fit into a minivan (if we break down the pipes into smaller pieces)

Large stage orders will require a rental U-Haul or similar.

If you have concerns, we always can offer our delivery and or pick up services for an additional charge.

## **Do you sell any of your gear used?**

Sometimes! Please let us know what you are looking for. If we don't have it used we almost always can get you a new price.

## **I'm confused with these lighting terms... help!**

Not to worry! Here is a handy glossary ☺

**Console or Controller:** Provides a control signal to an AC dimmer or fixture which enables the user to set the levels for lighting cues.

**Dimmer:** A device for alternating the AC output that allows lights to be made dimmer or brighter

**DMX:** is a standard for digital communication networks that are commonly used to control stage lighting and effects. It was originally intended as a standardized method for controlling light dimmers, which, prior to DMX512, had employed various incompatible proprietary protocols.

**Edison Cable:** Cable used to supply power to lights. It has connectors at either end which are like your standard household receptacles. Also known as an extension cord.

**Ellipsoidal:** Also called a Leko; a lighting instrument which projects a beam of light at a specific length and angle. It has a focusable hard edge beam and may be shaped using shutters. It has a slot for a Gobo or pattern which projects an image.

**Fresnel (/f'reɪ'nɛl/ fray-NEL or frɛznəl/ FREZ-nəl) :** A lighting instrument with a lens recognized by its concentric rings. The Fresnel light produces a soft edge beam of light and can be focused from spot to wash.

**Gobo:** A pattern cut or etched out of thin metal used to project shapes, custom designs or logos. A gobo is placed into a pattern holder and fitted into an ellipsoidal or moving light fixture. Gobos come in many different sizes for different lighting fixtures.

**Lamp:** The correct term for a light bulb.



**LED: Light Emitting Diode.** LED instruments can and have been used to replace any conventional lighting fixtures. LED instruments can contain a number of different colored LEDs, often Red, Green and Blue (sometimes to include White, Amber and UV), and different light output colors can be achieved by adjusting the intensity of each LED color group. LED instruments should have a long service life relative to other options, without the expense of color gel or replacement lamps.

**Leko:** See Ellipsoidal

**PAR: Parabolic Aluminized Reflector.** A lighting fixture which emits a diffused oval beam of light.

**Riser, Deck or Platform:** A stage piece that can be several different dimensions and heights. Typical dimensions include 4' x 8', 4' x 4', 2' x 8' and 2' x 4'. Typical heights include 1', 2', and 3'. These platforms can be joined together to make just about any size stage that you may require. Custom heights up to 20' tall can be provided.

**Uplight:** A light that is placed on the ground to illuminate a wall. Typically a Par or LED light.

## Ellipsoidal Spots

All Ellipsoidals come with SPG connectors and include color frame, c-clamp and safety cable.

ETC Source Four – 575 watt or 750 watt

19 degree \$30.00  
26 degree

\$30.00  
36 degree \$30.00  
50 degree \$30.00  
90 degree \$40.00  
10 degree \$40.00  
5 degree \$45.00



Source Four Lens Tube only

Specify 19, 26, 36, or 50 degree \$15.00  
90 degree \$17.00  
10 degree \$22.00  
5 degree \$27.00

ETC Source Four LED Lustr+ 2

Specify 19, 26, 36 EDLT \$150.00  
Includes Powercon to Edison

Source Four Enhanced Definition Lens Tube only

19 degree \$30.00  
26 degree \$30.00  
36 degree \$30.00

ETC Source Four Zoom

15 – 30 degree \$40.00  
25 – 50 degree \$40.00

ETC Source Four Jr. Zoom

\$30.00

## Fixture Accessories

Iris for Source Four \$ 6.00  
Pattern Holder ETC \$ 1.50  
Pattern Holder ETC Glass \$ 3.00  
Donut 7.5" \$ 1.00  
Donut 6.25" \$ 1.00  
Donut 5 or 10 degree Source Four \$ 2.00  
Color Extender (Rosco) \$ 2.00  
Tophat ETC \$ 3.00  
Tophat 7.5" \$ 3.00  
Barndoor 7.5" & 10" \$ 4.50  
Barndoor Strand 10" \$ 8.00  
Barndoor Source Four Par \$ 5.00  
Floor Base Wooden \$ 1.25  
Floor Base Metal \$ 1.50  
Dual Fixture Bar \$ 2.00  
Ultimate Support Stand w/ 2 cross bars \$ 25.00



## Hanging Hardware

Bale Block – 5/8" receiver \$ 1.00  
Scissor Clip w/ 5/8" spud \$ 1.50  
Scissor Clip w/ cable hook \$ 1.50  
Stiffener Side arm 1" pipe \$ 2.00  
Single tee side arm \$ 1.25  
Double tee side arm \$ 1.50

## Fresnels

All Fresnels come with SPG connector and include color frame, c-clamp and safety cable.

6"Altman 500/750/1000 watt \$20.00  
6"Strand 500/750/1000 watt \$20.00  
8"Altman 1000 watt \$22.00  
8"Strand 1000/ 2000 watt \$37.00



## Incandescent Par Fixtures

All Par fixtures include color frame, c-clamp and safety cable.

Par 20 PBG 100 watt  
NSP, MFL, WFL \$ 6.00  
Pinspot PBG 30 watt 12 volt \$ 6.00  
LED Pinspot \$ 8.00  
Par 38 PBG 150/ 250 watt \$ 10.00  
Par 46 PBG 200 watt  
NSP, MFL, WFL \$ 10.00  
Par 56 PBG 300/ 500 watt \$ 11.00  
(Specify NSP, MFL, WFL)  
Par 64 SPG 500/1000 watt \$ 12.00  
(Specify Silver or Black and NSP, MFL, WFL, VNSP)  
Source Four Par 575 watt \$ 18.00  
(Specify clear, VNSP, NSP, MFL, WFL)  
Source Four Par Lens Kits (4 piece) \$ 8.00  
Par Bar with 6 Par 64's Socopex \$ 75.00  
Par Bar with 6 ETC Pars Socopex \$ 95.00  
ACL Bar with 4 Par 64 ACL SPG \$ 60.00  
ACL Bar with 4 Par 46 ACL SPG \$ 40.00  
Pinspot Bar 10 lamp PBG 500 watt \$ 65.00  
Audience Blinder 8-Lite \$ 75.00



## LED Par Fixtures

### ColorKinetics

Color Blast 12 w/ accessory holder \$ 35.00  
iW Blast 12 TR (Variable White LED's) \$ 45.00  
36\*/50\* horizontal spread lens \$ 5.00  
Color Dial \$ 25.00  
Keypad (pre-programmed 8-looks) \$ 25.00  
ColorPlay by request (12 pkg minimum) \$ 25.00  
PDS-375-TR 6-way power supply \$ 25.00  
PDS-750-TR 12-way power supply \$ 35.00

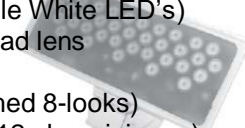

### ETC

D40 Vivid \$5 5.00  
Spread Lens (25\*, 45\*, or 75\*)

### LED Striplights

Elation DLED60 Striplight \$ 45.00



### American DJ LED

ADJ 5P Hex 6-in-1 LED \$ 25.00  
7PZ IP RGBW 5-50\* Zoom \*Outdoor Rated\* \$ 65.00

### Blizzard Lighting

LB Hex Par 6-in-1 \$ 35.00  
Puck3 Unplugged RGB \*Battery\* \$ 45.00

**Floods**

All floods include c-clamp and safety cable. All scoops include a color frame.

10" Scoop 400 watt PBG	\$ 12.00
14" Scoop Incandescent or Focusing 1000 watt SPG	\$ 20.00
Blizzard LED SnowBank	\$ 30.00

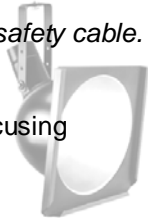
**Cyc Lights**

All Cyc lights include clamp, safety, and color frame.

Broad Cyc 1 cell 1000 watt SPG	\$ 17.50
Broad Cyc 2 cell 1000 watt SPG	\$ 35.00
Broad Cyc 3 cell 1000 watt SPG	\$ 52.50
Broad Cyc 4 cell 1000 watt SPG	\$ 70.00
Altman L.E.D SpectraCyc (outdoor rated)	\$100.00

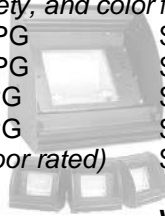
**Striplights**

Elation DLED60 LED Striplight	\$ 45.00
-------------------------------	----------

**Opto Isolator, Demux, Wireless DMX**

EDI Opto Isolator 8-way DMX	\$ 50.00
Elation 5pin DMX Splitter 6-way	\$ 30.00
ADJ 3pin DMX Splitter 6-way	\$ 30.00
Serial Data Splitter 6 way 3XLR	\$ 50.00
Marconi Wireless DMX Transmitter/Receiver	\$ 60.00
City Theatrical ShowBaby Wireless DMX	\$ 50.00
City Theatrical ShowNeo Wireless DMX	\$ 60.00

(Transmitter or receiver. Works with ShowBaby)

**Search Lights**

Cirrus 850w Searchlight 120v Single Beam Searchlight	Per 4 Hours \$300.00
---	-------------------------

**Follow Spots**

Includes 5 to 6 standard colors. Customs colors provided at an additional charge.

75' maximum throw

Lycian Midget	\$ 55.00	\$ 82.50	\$ 96.25
---------------	----------	----------	----------

130' maximum throw

Phoebus Ultra Quartz	\$ 65.00	\$ 97.50	\$ 130.00
Phoebus IMARC	\$ 65.00	\$ 97.50	\$ 130.00
Altman Comet	\$ 65.00	\$ 97.50	\$ 130.00

200' maximum throw

Lycian Short Throw 1266			\$ 200.00
-------------------------	--	--	-----------

350' maximum throw

Lycian Long Throw 1267			\$ 250.00
------------------------	--	--	-----------

500' maximum throw

2K Xenon Super Trouper	\$ 275.00	\$ 343.75	\$ 440.00
------------------------	-----------	-----------	-----------

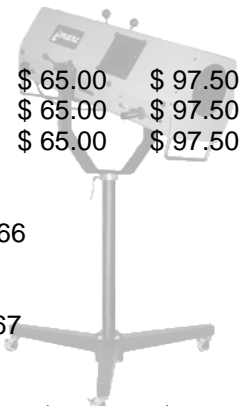
**Uplighting Kits****Uplight Kit #1 (Good For Light Colors)**

12- Par 38 250w	\$100.00
12- Floor Base	
6- 25' Edison PBG Cable	
6- Tri-Tap Edison	
<i>Gels sold separately</i>	

**Uplight Kit #2**

12- Blizzard LB Hex Par RGBAW+UV	\$400.00
12- PowerCon to Edison adapters	
12- 25' 3XLR Control Cable	
12- 10' Edison PBG Cable	
1- ETC SmartFade 12/48 Controller	

**Uplight Kit #2.2**

12- Blizzard LB Hex Par RGBAW+UV <i>Preset to 1 of 63 color choices</i>	\$300.00
12- PowerCon to Edison adapters	

**Uplight Kit #3**

12- Color Kinetics ColorBlast 12 RGB	\$300.00
12- 25' 4XLR Cable	
1- 12 Way Power Supply	
1- 50' Edison PBG Cable	
1- 50' DMX Control cable	
1- Elation LED Operator (EZ LED Controller)	

**Uplight Kit #4**

12- ETC Desire Vivid D40 LED	\$500.00
11- 25' PowerCon/DMX Combo Cable	
2- 50' Edison	
1- ETC Smartfade 12/48 DMX Console	

**Uplight Kit #5 (Battery)**

12- Blizzard Puck 3 Unplugged <i>Pick from 15 preset colors</i>	\$400.00
--	----------

**Uplight Kit #6**

8- ADJ 5P Hex <i>Preset to selected color</i>	\$150.00
--	----------

## Stage Lighting Kits

### Week

#### Basic Stage Lighting Kit

\$300.00

*This kit comes with a total of 8 incandescent instruments. Please choose a combination of lekos, fresnels or Par's, all lamped at 575 watts or less.*

- 2- 12' Pipe w/ base and crossbar
- 8- Instruments 575 watt max
- 2- LD340 Dimmers
- 1- NSI 7008 Controller
- 2- 50' Edison PBG Cable
- 1- 100' DMX Cable
- 1- 50' DMX Cable
- 4- 35# Sandbags

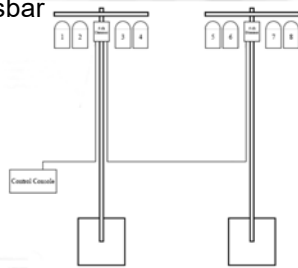

#### ETC LED Stage Wash Lighting Kit

\$450.00

- 2- 12' Pipe w/ base and crossbar
- 8- ETC Desire D40 Vivid LED Pars
- 8- Choice of 25, 45 or 75 degree lens
- 6- 10' Power-con jumpers
- 2- 100' Edison PBG Cable
- 2- Edison to Power-con Adapters
- 1- ETC SmartFade 12/48 Console
- 6- 10' DMX
- 1- 50' DMX
- 1- 100' DMX

#### Blizzard LED Stage Lighting Kit

\$350.00

- 2- Ultimate Support Stands
- 8- Blizzard LB Hex Pars
- 6- 10' Power-con jumpers
- 2- 100' Edison PBG Cable
- 2- Edison to Power-con Adapters
- 1- ETC SmartFade 12/48 Console
- 6- 5' XLR
- 1- 50' XLR
- 1- 100' XLR

#### Large Stage Lighting Kit

\$450.00

*This kit comes with a total of 16 instruments. Please choose a combination of lekos, fresnels or Par's, all lamped at 575watts or less.*

- 3- 12' Pipe w/base and 2 crossbars
- 16- Instruments 500 watts
- 16- Edison Adapters
- 4- NSI 4600 Dimmer
- 4- 50' Edison Cable
- 2- 5' 3XLR Cable
- 1- 100' 3XLR Cable
- 1- 50'3XLR Cable
- 8- 35# Sandbags
- 1- NSI 7016 Controller

#### Professional Stage Lighting Kit

\$875.00

*This kit comes complete with 40' of truss, 24 – Par64's on lamp bars, 12 channels of dimming and control. Please choose from the option of ground support or chain motors.*

- 4- 12" Box Truss
- 4- Par Bars w/ 6- Source4 Par 575w
- 1- CD80 12 x 2.4 kw
- 1- Leprecon 12 Channel DMX Controller
- 1- 100' DMX Control Cable
- 2- 125' Socopex
- 2- 100' Socopex
- 4- Breakins
- 5- 25' #2w Camlok
- 5- #2w Camlok Pigtails
- 16- Truss Protectors
- Color Assortment
- Option, Choose one of the following:*
- 2- Duratruss 5200 16' crank lifts
- 2- 1 Ton Chain hoist w' Rigging Package

*Packages can be customized to fill a customers needs at a nominal fee.*

#### Film Lighting Kits

Week

Rosco LitePad Vector CCT Kit

\$150.00

#### Stringer Lights

Week

- 46' Mini Twinkle Lights (100 per strand) \$ 6.00
- 25' Clear Party Lights (7 watt per bulb) \$ 6.00
- 9' Icicle Lights (150 per strand) \$ 6.00
- 4' Light Curtains (100 per strand) \$ 6.00
- 54' Canopy Stringer Lights (24-11watt lamps) \$30.00
- 106' Canopy Stringer Lights(50-11watt lamps)\$60.00

#### Flicker Effect

Week

GAM Flicker Generator SPE – 6

\$75.00



<b>Special Effects</b>	<b>Week</b>
Oscillating Pinstop	\$ 8.00
8" Police Beacon (red, blue, green, amber)	\$ 20.00
12" Police Beacon (red, blue, green, amber)	\$ 25.00
Mystic LED	\$40.00



<b>Bubbles/Flames</b>	<b>Week</b>
Bubble Blast	\$ 60.00
Bubble Max 2X	\$ 50.00
Le Flame Fire Bowl	\$ 35.00
Rosco X24 (Fire/water/Aura Borealis)	\$150.00
Gam FilmFX (Flames/Water/Bubbles)	\$ 75.00
Gam SX4	\$ 75.00

<b>Lasers</b>	<b>Week</b>
Blisslight 15 / 50 (Blue Nebula effect with Green laser stars)	\$35.00 / \$45.00
American DJ Galaxian DMX (Red & Green Moving Star Laser Effect)	\$ 45.00
Atmospheric RG LED Laser (Red/Green "Web" laser & Blue "smoke" effect LED)	\$ 45.00
Royal Sky Laser (Green & Violet Blue Sky Effect Laser)	\$ 45.00
ADJ Inno Pocket LZR <b>NEW!</b>	\$ 50.00

<b>Smoke &amp; Fog Machines</b>	<b>Week</b>
(Fog fluid is not included unless noted.)	
Rosco Delta 3000 DMX w/Timer Remote	\$ 75.00
Rosco Vapour	\$ 55.00
Rosco Vapour Plus	\$ 75.00
Ultra-Tec G3000 2kw Fog Machine	\$100.00
Antari Z-1020 Vertical Fogger	\$ 75.00



<b>Haze Machines</b>	<b>Week</b>
(Haze Fluid not included)	
ReelFX DF-50 Hazer Oil Based	\$125.00
ReelFX DF-50 DMX Interface	\$ 25.00
Magna Prime Elation	\$45.00
Vertical Hazer Antari	\$40.00

<b>Low Lying Fog Machines</b>	<b>Week</b>
(Dry ice or required fluid is not included)	
Aqua Fogger Dry Ice Machine	\$125.00
Le Maitre LSX	\$200.00
Rosco Chiller Module	\$ 30.00

<b>Snow Machines</b>	<b>Week</b>
Antari S-100 II Snow Machine (Fluid Not Included)	\$ 75.00
Confetti Spinner (Artificial Snow Not Included)	\$ 75.00

<b>Intelligent Lighting</b>	<b>Week</b>
Martin MAC 2K Profile	\$400.00
Martin MAC 250 Entour	\$350.00
ADJ VIZI BSW300 LED *Beam/Spot/Wash*	\$150.00
ADJ RXONE Beam Profile	\$ 75.00
ADJ Inno Pocket Wash LED	\$ 50.00
ADJ Inno Pocket Spot LED	\$ 50.00
ADJ Inno Pocket LZR LED	\$ 50.00

<b>Intelligent Lighting Consoles</b>	
Whole Hog II	\$500.00
Hog IPC	\$625.00
HedgeHog 4	\$300.00
ETC Ion 24 Moving Light Board	\$300.00
ETC Smartfade ML 24 Moving Light Board	\$125.00
ADJ MyDMX 3.0 (laptop not included)	\$ 50.00
ADJ AirStream Bridge – iOS compatible only	\$ 25.00
Swisson DMX Recorder 4 SHOW	\$ 50.00

<b>Music Stands &amp; Lights</b>	<b>Week</b>
Music Stand	\$ 5.00
Music Stand Light	\$ 2.00
Conductor's Music Stand	\$ 7.00



<b>Confetti Cannons (Confetti Not Included)</b>	<b>Week</b>
Confetti Cannon (tank and hose included)	\$ 75.00
Confetti Spinner	\$ 75.00
A/C Air Launcher	\$ 75.00

<b>Clearcom</b>	<b>Week</b>
A headset is included with rental of base station or belt pack.	
CS –222 Base Station	\$ 50.00
RS – 501 Single Channel Belt pack	\$ 25.00
RS – 602 Single Dual Listen Belt pack	\$ 50.00
CC – 85 Single Muff Headset	\$ 15.00

**Mirror Balls & Accessories**

- 20" Ball w/ motor
- 16" Ball w/ motor
- 12" Mirror Ball



<b>Week</b>
\$40
\$30
\$25

Pinspot w/ clamp \$ 6.00

- Pinspot (tabletop) \$ 6.00
- LED Pinspot \$ 8.00
- Large Mirror Ball Motor \$ 10.00
- Small Mirror Ball Motor \$ 5.00
- Jewelers Turntable \$ 10.00



**Fans & Wind Machines**

Mole E Fan (Variable Speed Wind Machine) \$100.00

<b>Week</b>
\$100.00

**Motion Effects**

- GAM Twin Spin II (0.9 – 9.0RPM) \$ 50.00
- Apollo Smart Move \$ 50.00
- GAM Film/FX \$ 25.00
  - Loops sold separately
- GAM SX4 Film Driver w/ fixture \$ 75.00
  - Include in stock loops only
- Rosco Image Pro \$ 40.00
  - IP slide and kits sold separately
- Rosco X-Effects DMX \$150.00
  - Choose from 19", 30", 50", 70"
  - Water or fire effects
- Rosco I-Cue \$ 50.00
- PSU-50 for I-Cue \$ 15.00



**Blacklights**

- 4' Fluorescent Tube \$ 20.00
- Wildfire 250w Flood \$ 50.00
- Wildfire 400w Flood \$100.00
- ADJ UV COB Cannon \$ 35.00



<b>Week</b>
\$ 20.00
\$ 50.00
\$100.00
\$ 35.00

**Strobe Lights**

- AM DJ Mega Flash 800w DMX strobe \$ 30.00
- Data Flash AF1000 DMX \$ 50.00
- AF1000 Mini Controller \$ 45.00
- Mini Strobe \$ 15.00
- Star Strobe \$ 4.00
- FREQ 16 LED Chasing Strobe \$ 35.00
- FREQ Matrix Strobe/Blinder \$ 45.00
- Matrix Beam LED \$ 55.00
- Matrix Beam Package (4) \$200.00

<b>Week</b>
\$ 30.00
\$ 50.00
\$ 45.00
\$ 15.00
\$ 4.00
\$ 35.00
\$ 45.00
\$ 55.00
\$200.00

**Dimming**

- NSI ND 4600 4 x 600 watt PBG 3XLR \$ 35.00
- NSI ND 5000 4 x 600 watt PBG 3XLR \$ 35.00
- NSI DDS 6000+ 4 x 1200 watt PBG 3XLR \$ 45.00
- NSI DDS 8600 6 x 1800 watt SPG DMX \$ 65.00
- Leprecon LD 340 4 x 600 watt SPG DMX \$ 35.00
- Leviton D4 DMX 4 x 600 watt PBG DMX/XLR \$ 35.00
- Strand CD-80 12 x 2400 watts SPG DMX \$150.00
- Strand CD-80 6 x 2400 watts \$150.00
  - 60 amp SPG DMX
- Strand CD-80 24 x 2400 watts Socopex DMX \$ 250.00
- Strand CD-80 48 x 2400 watts SPG Socopex DMX \$ 600.00
- SDSL 600w Variac Dimmer \$ 5.00

<b>Week</b>
\$ 35.00
\$ 35.00
\$ 45.00
\$ 65.00
\$ 35.00
\$ 35.00
\$150.00
\$150.00
\$ 250.00
\$ 600.00
\$ 5.00

**Lighting Consoles**

- Whole Hog II \$ 500.00
- Hog IPC \$ 625.00
- HedgeHog 4 \$ 300.00
- ETC Ion Moving Light Board \$ 300.00
- ETC Smartfade ML 24 \$ 125.00
- ETC Smartfade 12/48 \$ 80.00
- ETC Smartfade 24/96 \$ 100.00
- ETC Express 250 DMX \$ 225.00
- ETC Expression 250 channel DMX, AMX \$ 250.00
- ETC Expression 2x DMX, AMX \$ 400.00
- Leprecon 612 12 channel DMX, 3XLR \$ 40.00
- Leprecon 624 24 channel DMX, 3XLR \$ 80.00
- Elation LED Operator \$ 30.00
  - (Controls any three channel LED)
- NSI 7008 8 channel x 2 scene \$ 30.00
- NSI 7016 16 channel x 2 scene \$ 35.00
- NSI 7024 24 channel x 2 scene \$ 40.00
- ADJ MyDMX 3.0 \$ 50.00



*Software based, Laptop not included*

- ADJ AirStream Bridge – iOS compatible only \$ 25.00
- ETC Colorsources Console \$ 150.00

**Moving Light Cable**

20 amp 250 volt L6-20  
 25'  
 50'  
 75'  
 100'  
 125'



**Week**

\$ 3.00  
 \$ 6.00  
 \$ 9.00  
 \$12.00  
 \$15.00

**Socopex Cable**

25' 6 circuit 2 kw  
 50' 6 circuit 2 kw  
 75' 6 circuit 2 kw  
 100' 6 circuit 2 kw  
 125' 6 circuit 2 kw  
 150' 6 circuit 2 kw

**Week**

\$ 5.00  
 \$10.00  
 \$15.00  
 \$20.00  
 \$25.00  
 \$30.00

Breakin 6 circuit to male SPG  
 Fanout 6 circuit to female SPG

\$10.00  
 \$10.00

Breakin 6 circuit to male PBG  
 Fanout 6 circuit to male PBG

\$10.00  
 \$10.00

Socopex 2-fer

\$20.00

**Control Cable**

3 XLR Microplex

5'  
 10'  
 15'  
 25'  
 50'  
 100'

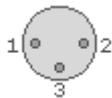

\$ 1.00  
 \$ 1.00  
 \$ 1.00  
 \$ 1.25  
 \$ 2.50  
 \$ 5.00

4 XLR AMX

5'  
 10'  
 15'  
 25'  
 50'  
 100'

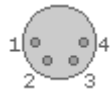

\$ 1.00  
 \$ 1.00  
 \$ 1.00  
 \$ 1.25  
 \$ 2.50  
 \$ 5.00

5 XLR DMX

5'  
 10'  
 15'  
 25'  
 50'  
 100'

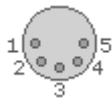

\$ 1.00  
 \$ 1.00  
 \$ 1.00  
 \$ 1.25  
 \$ 2.50  
 \$ 5.00

**Cable**

PBG Cable Edison 12/3 20 amp  
 5'  
 10'  
 15'  
 25'  
 25' Flat  
 50'  
 100'

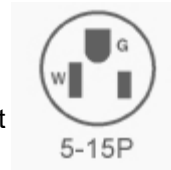

**Week**

\$ 1.00  
 \$ 1.00  
 \$ 1.00  
 \$ 1.50  
 \$ 1.50  
 \$ 3.00  
 \$ 6.00

IEC Cable 14/3 (Interconnect Cable for LED's)

6'  
 15'

\$ 1.00  
 \$ 2.00

SPG Cable – Stage Pin 12/3 20 amp

5'  
 10'  
 15'  
 25'  
 30'  
 50'  
 75'  
 100'



\$ 1.00  
 \$ 1.00  
 \$ 1.00  
 \$ 1.25  
 \$ 1.50  
 \$ 2.50  
 \$ 3.75  
 \$ 5.00

20 amp Twist Lock

25'  
 50'  
 100'



\$ 1.75  
 \$ 3.50  
 \$ 7.00

Power-Con

5'  
 10'  
 25'

L5-20P

\$ 1.50  
 \$ 2.00  
 \$ 3.00

**Two- Fers & Adapters**

Edison Tri-Tap \$ 1.00  
 Stage Pin Two-fer \$ 1.50  
 20 amp Twist Lock Two-fer \$ 1.50  
 Stage Pin 3-fer (block type) \$ 2.00  
 20 amp Twist Lock 3-fer \$ 2.00  
 60 amp SPG to 3-20 amp SPG \$ 5.00  
 Edison male to Stage Pin female \$ 1.00  
 Stage Pin male to Edison female \$ 1.00  
 Edison to Twist Lock 20 amp \$ 1.00  
 Twist Lock 20 amp to Edison \$ 1.00  
 Stage Pin to Twist Lock 20 amp \$ 1.00  
 Twist Lock 20 amp to Stage Pin \$ 1.00  
 Stage Pin to Quad Box \$ 2.00  
 Edison to Quad Box \$ 2.50

Power Strip 15 amp breaker \$ 3.00

*Other adapters may be available on request*

<b>Distribution Panels</b>	<b>Week</b>
<i>All Three Phase Panels have a maximum load of 100 amps regardless of the number of outputs.</i>	
Mini Panel – 10/5 in / 3 - 12/4 out	\$ 25.00
CS 50 amp in / 5 - 12/4 out	\$ 35.00
CS 50 amp in / 8 - Edison out	\$ 35.00
Camlok in / 6 - 12/4 out	\$ 50.00
Camlok in / 4 - 10/5 out	\$ 50.00
Camlok in / 12 – 15 amp Edison out	\$ 50.00

Tall Boy – Camlok in / 10 – 10/5 out \$175.00

*Several other Distribution Panels are available. Please Inquire.*

<b>Spider Panels</b>	<b>Week</b>
Camlok in /4 – 100 amp Camlok out	\$ 75.00
Camlok in /3 – 150 amp Camlok out	\$ 75.00

<b>Electrical Distribution</b>	<b>Week</b>
Camlok Tapping Tee	\$ 3.00
Camlok Parallel Tee	\$ 3.00
Camlok Two-fer	\$ 5.00
Camlok Three-fer	\$ 7.00

<b>Disconnect Switches &amp; Transformers</b>	<b>Week</b>
60 amp Switch – Breaker	\$ 30.00
100 amp Switch – Breaker	\$ 50.00
150 amp Switch – Breaker	\$ 60.00
175 amp Switch – Breaker	\$ 60.00
200 amp Switch – Breaker	\$ 75.00
225 amp Switch – Breaker	\$ 80.00
400 amp Fused Disconnect	\$100.00
600 amp Fused Disconnect	\$100.00
15 KVA, 480 to 208, 40 amp	\$ 75.00
75 KVA, 480 to 208, 200 amp	\$150.00
112 KVA, 480 to 208, 300 amp	\$200.00
150 KVA, 480 to 208, 400 amp	\$300.00
30 KVA 220/208 – 120 Isolation Transformer	\$100.00
5 Horse Power 3 – phase Air Compressor 20 CFM @100 PSI	\$200.00

<b>Cable Ramps</b>	<b>Week</b>
Heavy Duty Ramps – 3' – 5 Channel	\$ 15.00
Heavy Duty Ramps Ends – Pair	\$ 4.00
Light Duty Ramps – 3' – 2 Channel	\$ 7.00
Light Duty Ramp – 3' – 1 Channel	\$ 5.00

<b>Electrical Distribution</b>	<b>Week</b>
Tent Cable	
100' 15 amp PBG on 10' centers	\$25.00
150' 15 amp PBG on 10' centers	\$25.00
6/4 Cable – 50 amp TLG	
10'	\$ 5.00
25'	\$10.00
50'	\$20.00
75'	\$30.00
100'	\$40.00
10/5 Cable – 30 amp TLG	
10'	\$ 1.50
25'	\$ 3.75
30'	\$ 4.50
50'	\$ 7.50
75'	\$11.25
100'	\$15.00
Thru Box	\$ 5.00
End Box	\$ 5.00
Scatters	\$15.00
6/5 Cable – 80 amp Camlok	
50'	\$25.00
75'	\$37.50
100'	\$50.00
#2 W Camlok – 190 amp	
10'	\$ 3.00
25'	\$ 3.00
50'	\$ 6.00
100'	\$15.00
2/0 W or Entertainment Camlok – 300 amp	
10'	\$ 3.00
25'	\$ 7.50
50'	\$12.00
100'	\$17.50
4/0 W Camlok – 405 amp	
10'	\$ 5.00
25'	\$10.00
50'	\$15.00
75'	\$17.50
100'	\$20.00
Pigtails – Male or Female	
10/5 – 30 amp TLG	\$ 5.00
6/4 – 50 amp TLG	\$ 5.00
6/5 – Camlok	\$ 5.00
#2W Camlok	\$ 2.00
2/0 Camlok	\$ 2.00
4/0 Camlok	\$ 3.50

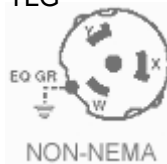

**Lifts & Towers**

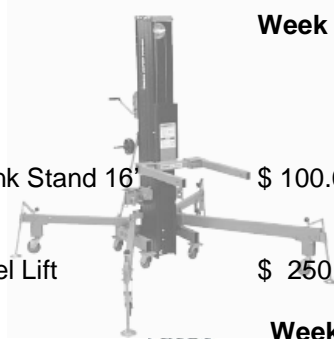

Duratruss Pro5200 Crank Stand 16'	\$ 100.00
Genie AWP30 Personnel Lift	\$ 250.00

**Truss**

10' x 12" Box Truss	\$ 70.00
8' x 12" Box Truss	\$ 70.00
6' x 12" Box Truss	\$ 70.00
5' x 12" Box Truss	\$ 40.00
4' x 12" Box Truss	\$ 40.00
3' x 12" Box Truss	\$ 40.00
2' x 12" Box Truss	\$ 40.00
6 – Way corner for 12" x 12" Box Truss	\$ 60.00
Base for 12" Box Truss 80#	\$ 30.00
10' x 20.5" Box Truss	\$ 90.00
Custom Truss (Complete with Par 64's)	
8' Double Hung	\$ 165.00
22' O.D 12" Circular Truss (8 sections) per section	\$ 95.00
Circle shade cloth	\$ 100.00

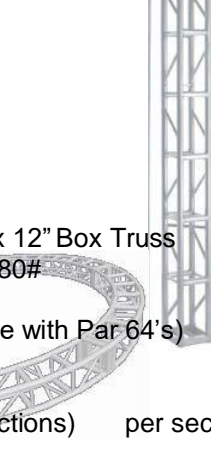

**Scaffold**

Scaffold Unit 5' x 7' x 5'H	\$ 80.00
Complete unit w/ frame, deck and safety rail	
Add set of caster	\$ 15.00
Scaffold Unit 5' x 7' x 5'H	
Frame and cross braces only	\$ 35.00
5' x 5' Frame	\$ 15.00
5' x 30' Frame	\$ 5.00
7' Cross Brace	\$ 2.50
7' Aluminum Hook Plank	\$ 10.00
Casters – set of 4	\$ 15.00
18" Leveling Jack	\$ 3.50
Safety Rail & Post Set – 8 piece	\$ 10.00

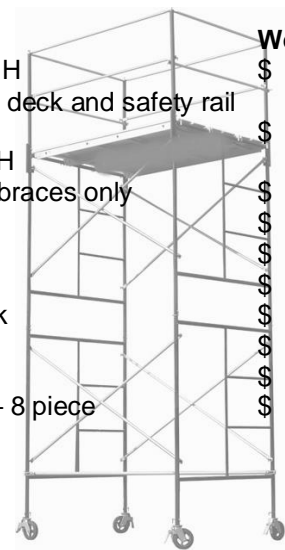

**Rigging & Chain Motors**

1 ton Chain Motor – 3 phase	\$125.00
Chain Motor Controller 8-Way	\$100.00
Chain Motor Controller 4-Way	\$ 75.00
Manual Chain Hoist 1-Ton 20'	\$ 35.00
Manual Chain Hoist 1-Ton 30'	\$ 40.00
18" Spanset	\$ 3.00
3' Spanset	\$ 3.00
6' Spanset	\$ 3.00
12' Spanset	\$ 4.00
5/8" Shackles	\$ 1.00
3/8" Shackles	\$ 1.00
Airwall Hanger for Instrument	\$ 5.00
Airwall Hanger w/ Chain	\$ 5.00
Airwall Hanger w/ Cheeseboro	\$ 5.00
Airwall Hanger w/ C-clamp	\$ 5.00
Beam Clamp (1 ton)	\$ 5.00
Beam Clamp (2-Ton)	\$ 10.00
Beam Clamp (3- Ton)	\$ 12.50
Tent Pole Clamps Small & Large	\$ 5.00
Tent Pole Hanging Ring (3' Diameter)	\$ 75.00
Rigging Steel 3/8"	
1.5'	\$ 1.50
2'	\$ 2.00
3'	\$ 3.00
5'	\$ 5.00
10'	\$ 10.00
20'	\$ 20.00



**Pipe & Pipe Hardware**

1 1/2" Schedule 40 Pipe (price is per foot)	\$ 2.00
2' to 21' lengths	
Pipe coupling	\$ .50
End cap with ring	\$ 1.00
Rigid Cheeseboro	\$ 2.50
Swivel Cheeseboro	\$ 2.50
Truss Cheeseboro	\$ 3.00
80# Base	\$ 15.00
50# Base	\$ 15.00



**Trade Show & Party Equipment**

Clamp on style fixture with 150 watt lamp	\$ 3.50
Clamp on style fixture with MR16 lamp	\$ 5.00
Exit Sign – Nuclear	\$ 35.00
Buffet Booms (8' with 3- Par 20's)	\$ 60.00

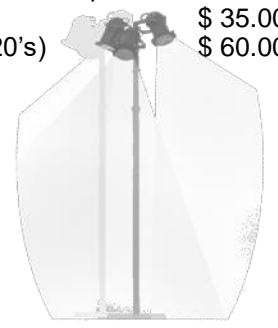

<b>Steel Deck Stage Risers</b>	<b>Week</b>
4' x 8' Steel Deck Riser	\$ 4 5.00
12", 18", 2', 3', 4', legs (please specify)	
4' x 4' Steel Deck Riser	\$ 3 5.00
2' x 8' Steel Deck Riser	\$ 4 0.00
2' x 4' Steel Deck Riser	\$ 3 5.00
Couplers	\$ 3.50
Screw Jacks	\$ 5.00
4' Safety Rail (must be rented when over 40")	\$ 2 5.00
Adjustable 7 Step Unit (up to 5')	\$135.00
Adjustable 5 Step Unit (up to 4')	\$ 1 0 0.00
1 Step Unit – 7"	\$ 2 0.00
2 Step Unit – 14"	\$ 2 0.00
Steel Deck 2' step unit	\$ 4 5.00
Steel Deck 3' step unit w/ handrails	\$ 6 0.00
30" round Turntable 5 rpm (200# maximum)	\$ 8 5.00

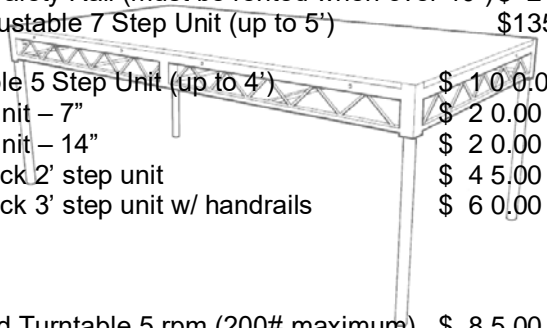

Custom risers can be manufactured and will be quoted on request.

<b>Staging Accessories</b>	<b>Week</b>
Black Velcro Banjo Skirting 25' Section	\$ 35.00
1" Velcro Strips included	

<b>Choir Risers</b>	<b>Week</b>
<i>Choir Risers are box types risers, not folding</i>	
Choir Riser – 4' x 8' with 3 rises of 7" each	
Treads are 16" wide.	\$ 55.00
Steel Deck 2' x 8' risers	\$ 40.00

Please inquire for pricing on custom Choir or seating risers!

<b>Drapery Hardware</b>	<b>Week</b>
SDSL Telescoping Stand requires	
35#base	\$8.00
3' to 5'	
5' to 8'	\$8.00
8' to 15'	\$9.50
10' to 18'	\$10.00
Innovative Systems Stand	
8' to 14'	\$ 10.00
Expander 6' to 10'	\$ 3.50
Expander 7' to 12"	\$ 3.50
Expander 8' to 14'	\$ 3.50
35# Base	\$ 6.00
17.5# Base (w/ 2" O.D. x 6" Spud)	\$ 6.00
Traveler Track (unassembled, per foot)	\$ 8.00
<i>Specify Bi-Parting, Side pull or Walk-a-long</i>	
<i>Black handline is sold per foot for this renta</i>	

<b>Drapes</b>	<b>Week</b>
Black Encore Speed Drape	
10' x 15'	\$ 55.00
14' x 15'	\$ 75.00
Black Encore Legs	
18' x 25' 50% Fullness	\$195.00
18' x 10' 50% Fullness	\$ 95.00
Pewter Encore Speed Drape	
16' x 15'	\$ 85.00
Super-Vel Speed Drape (Crushed Velour)	
16' x 5' Royal Blue	\$ 30.00
16' x 5' Wine	\$ 30.00
14' x 5' White	\$ 30.00
14' x 15' White	\$ 70.00

<b>Cycloramas</b>	<b>Week</b>
Natural Muslin Cyc	
16' x 32'	\$200.00

Drapes are available in other sizes and colors and types. Please inquire for price and availability

**Please Note: Rental Prices do not include Labor. Please inquire about our labor rates.**

1. SDSL uses great care to have all equipment in good order and repair, gives no warranty expressed or implied, as to condition or quality of any other matter of any equipment rented, and will in no way be responsible for damages resulting while in user's possession. All returns are subject to inspection.
2. RENTAL RATES AND PERIODS. Rental rates are established for single day, single week and for multiple week periods. All charges are based on the time in the LESSEE's possession whether in use or not.
3. All rentals are due back by close of business on day that contract expires.
4. In the event the renter fails to return said item(s) at agreed time, or fails to abide by any other terms of this contract, the rental agent (SDSL) may repossess it without notice to renter, and the rental agent (SDSL) is hereby released from all claims arising there from.
5. Any item(s) not returned by the agreed time shall have additional charges accrue until the missing items are returned. These charges shall be determined by the rental agents published rates. Any item not returned within seven (7) days after agreed due date shall be charged to the renter at the retail replacement cost. NO credit will be allowed for the rental cost.
6. The security deposit, if required will be refunded upon return of all rental items herein described, if all obligations and regulations of this agreement have been satisfied and adhered to by the renter. All DEPOSITS are non-refundable 48 hours before scheduled event of said contract or agreement commences.
7. Any spare lamps or equipment must be returned with rental package. If spares are used, the burned-out lamps must be returned with hereby rental or full retail replacement cost will be charged. This applies to any item marked spare on rental contract.
8. The renter agrees to insure said property against all risks of loss or damage in a sum of not less than the total aggregate equipment value or the actual current retail value of such equipment, with an insurance carrier acceptable to SDSL and, at the option of SDSL, to supply a certificate for same. Renter hereby assumes the entire risk of loss, damage or destruction of equipment from any and every cause whatsoever commencing with delivery of said equipment to renter, and renter shall (except to the extent proceeds of insurance provided by renter cover such loss) at SDSL'S option (a) repair fully such item, (b) pay SDSL all unpaid rental and/or current equipment replace value in cash (c) replace such item with a like item acceptable to SDSL, or such combination of above.
- 9. RENTER/PURCHASER agrees to operate said equipment only in the manner for which it was intended. RENTER agrees not to attempt to make any repairs or alternations of any nature, kind or description and in the event that rental equipment becomes inoperative, SDSL is to be notified at once. 619- 299-2300.**
10. You understand there are risks in and around staging and lighting equipment. By signing this agreement, you (and the Equipment users) agree not to sue SDSL for any reason. YOU AGREE TO ASSUME ANY AND ALL RISKS (both primary assumption and secondary assumption of the risk) INVOLVED WITH OR ARISING FROM YOUR USE OF THE RENTAL EQUIPMENT DESCRIBED ABOVE (hereinafter, including, but not limited to: the risks of death, bodily injury, property damage, falls, collisions with stationary objects, the unavailability of emergency medical care, and/or the negligence and/or deliberate act(s) of any other person, firm, or company (actual damages, consequential lost profits, electric shock, trip and fall, misuse of product.
- AS A CONSIDERATION FOR BEING PERMITTED BY SDSL TO RENT ITS EQUIPEMT, YOU HEREBY AGREE THAT YOU, YOUR ASSIGNESS, HEIRS, SUCCESSORS, DISTRIBUTEES, GUARDIANS, AND LEGAL REPRESENTATIVES WILL NOT MAKE A CLAIM AGAINST OR SUE SDSL OR ATTACH THE PROPERTY OF SDSL FOR ANY INJURY OR DAMAGE RESULTING FROM THE NEGLIGENCE OR OTHER ACTS, HOWSOEVER CAUSED BY THE EMPLOYEES, AGENTS, CONTRACTORS, OR OTHER REPRESENTATIVES OF SDSL, OR RESULTING FROM ANY DEFECT IN THE EQUIPMENT RENTED BY YOU UNDER THIS AGREEMENT. YOU HEREBY RELEASE SDSL AND ANY OF ITS EMPLOYEES, AGENTS, CONTRACTORS, OR OTHER REPRESENTATIVES FROM ALL ACTIONS, CLAIMS, OR DEMANDS THAT YOU OR ANY OF YOUR ASSIGNEES, HEIRS, SUCCESSORS, DISTIBUTEES, GUARDIANDS OR LEGAL REPRESENTATIVE NOW HAVE OR MAY HEREAFTER HAVE FOR INJURY OR DAMAGE RESULTING FROM YOUR RENTAL OF STAGE AND LIGHTING EQUIPMENT, WHICH INCLUDES BUT IS NOT LIMITED TO: STAGES, TRUSSES, RIGGING, CHAIN MOTORS, DRAPERY & HARDWARE, ELECTRICAL DISTRIBUTION, LIGHTING, LADDERS, LIFTS.
11. You agree to indemnify and defend SDSL against, and hold harmless from, any and all claims, causes of action, damages, judgments, costs or expenses, including attorney's fees, which in anyway arise from or connected with your use of the rental property described above, whether such damage results from any negligent act or omission or is related to strict liability.
12. NO RETURNS without prior authorization. NO RETURNS of lamps, paint, gel, patterns, tape, books, fabric, videos or custom orders. ANY authorized return will be charged a 25% restocking fee or our costs incurred, whichever is greater.
14. ALL CABLE must be returned with at least one tie holding coil together. Failure to do so will incur additional charges.
15. ALL Drapery must be folded and put into respective bag. Failure to do so will incur additional charges. DO NOT use tape or staples on drapery. Drapery must be clean and dry. Additional charges for cleaning and fire retardant will be charged.

Instrument	Type	10'	20'	30'	40'	50'	60'
8" Fresnel	Spot Flood		6' 8'	10' 27'	13' 37'		
Source Four 90*	90 deg.	4'-7.5'	8'-15.1'	12'-22.6'	15'-28.3'		
Source Four 70*	70 deg.	5'-7'	10'-14'	15'-21'	20'-28'		
Source Four 50*	50 deg.	9'	18'	27'	36'		
Source Four 36*	36 deg.	6'	12'	18'	24'		
Source Four 26*	26 deg.		8.8'	13.2'	17.6'	22'	
Source Four 19*	19 deg.			9'	12'	15'	18'
Source Four 14*	14 deg.			30'-7.8'	50'-12.9'	70'-18.1'	90'-23.3'
Source Four 10*	10 deg.	55'-9.4'	70'-11.9'	85'-14.5'	100'-17'		
Source Four 5*	5 deg.			110'-13.2'	120'-14.4'	130'-15.6'	140'-16.8'
Source Four Zoom	15*/30* 25*/50*	6.5/9.3'	8.2/10.8' 8.8/18.6'	7.8/16.2' 13.2/27.9'	10.4/21.6' 17.6/37.2'	13/27' 22/	15.6/
Par 38	Spot Flood	6' 11'	12' 22'				
Par 46	NSP	3' x 4'	6' x 8'				
Par 46	MFL	4' x 7'	7' x 15'				
Par 56	NSP	3' x 6'	5' x 12'	8' x 17'	11' x 23'	13' x 29'	
Par 56	MFL	4' x 8'	7' x 15'	11' x 23'	14' x 31'	18' x 38'	
Par 56	WFL	6' x 13'	12' x 26'	18' x 39'	25' x 52'	31' x 65'	
Par 64	VNSP	2' x 4'	4' x 9'	6' x 13'	7' x 17'	9' x 21'	11' x 26'
Par 64	NSP	3' x 5'	5' x 9'	7' x 14'	10' x 19'	12' x 23'	15' x 28'
Par 64	MFL	4' x 8'	7' x 16'	11' x 24'	15' x 32'	19' x 40'	22' x 49'
Par 64	WFL	8' x 14'	17' x 29'	25' x 43'	33' x 57'	41' x 71'	50' x 86'
		2.5'	5'	7.5'	10'	12.5'	15'
10" Scoop	Flood	6'	13'	19'			
14" Scoop Inc.	Flood		10'	15'	20'	25'	30'
14" Focusing	Spot	9'	14'	18'	23'	27'	36'
14" Focusing	Flood	14'	21'	28'	34'	41'	55'
		6'	9'	12'	15'		
Source Four Par	VNSP	1.6'	2.3'	3.1'	3.9'		
Source Four Par	NSP	2'	3'	4'	5'		
Source Four Par	MFL	2.2' x 3.8'	3.2' x 5.8'	4.3' x 7.7'	5.4' x 9.6'		
Source Four Par	WFL	3.2' x 5.9'	4.8' x 8.8'	6.4' x 11.8'	8' x 14.7'		
		10'	20'	30'	40'	50'	
Source Four Jr. 26*	26 deg.		9.2'	13.8'	18.4'	23'	
Source Four Jr. 36*	36 deg.	6.8'	13.6'	20.4'	27.2'		
Source Four Jr. 50*	50 deg.	9.2'	18.4'	27.6'	36.8'		



